

Concentrated Light, Powerful Effects

MOVING HEAD BEAM 295W

YELLOW RIVER YR-295B



MOVING HEAD BEAM 295W

Elevate your performances with the explosive power of the YellowRiver YR-295B 295W Moving Head Beam. With a powerful 295W output, this light produces sharp, focused beams that cut through any space. Its diverse color system, combined with versatile gobos and prisms, creates dynamic patterns, vivid imagery, and captivating stage lighting



DURABLE AND MODERN DESIGN

The 295W Moving Head Beam features a robust and sturdy design. Its housing is constructed from high-grade, heat-resistant plastic, ensuring durability and impact resistance. The matte black finish adds a touch of elegance while preventing fingerprints and smudges. Weighing only 13.5KG and measuring 290 x 235 x 495mm, the YellowRiver YR-295B Moving Head Beam is remarkably lightweight and easily transportable between various stage or event locations.

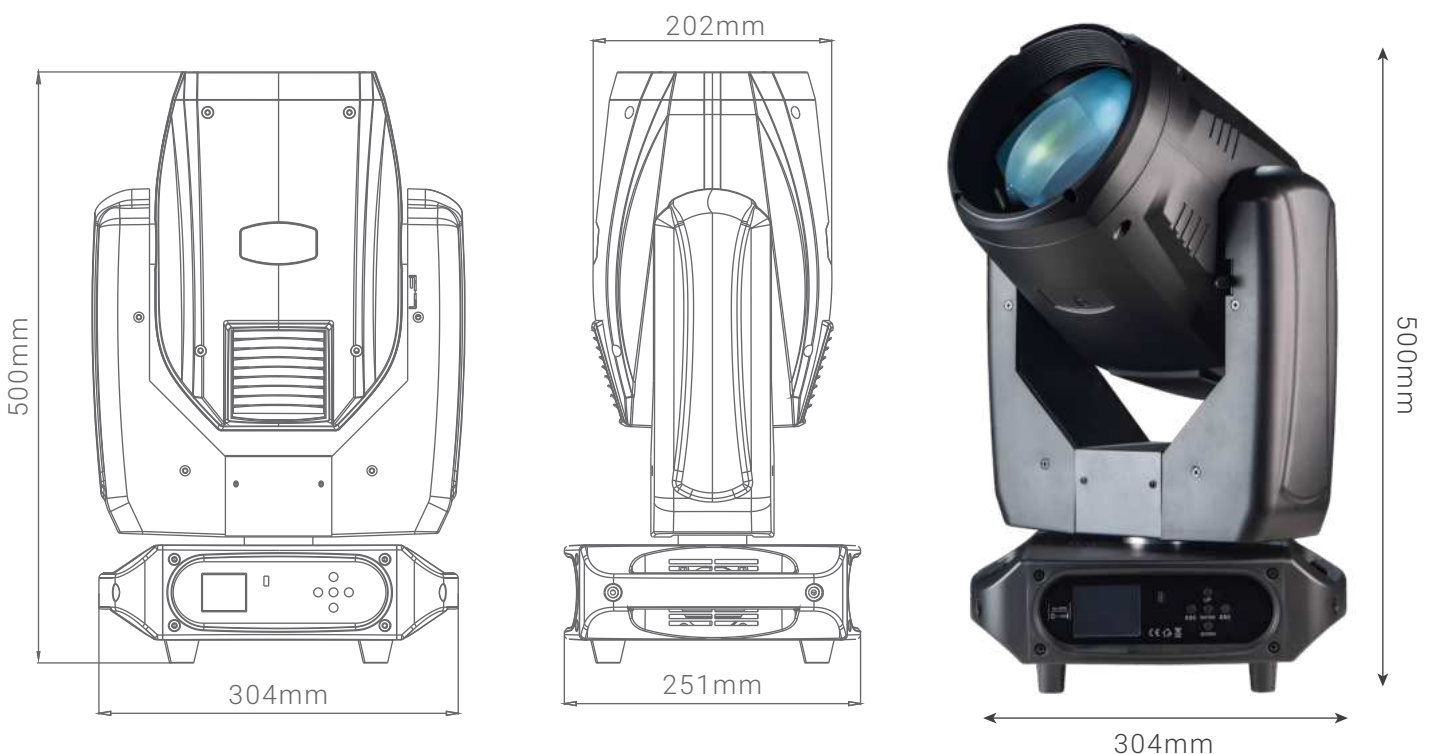

SHARP LIGHT SOURCE, HIGH POWER

The YR-295B Moving Head Beam utilizes an Osram Sirius HRI 295W lamp, capable of achieving a color temperature of 7800K to meet the demands of high-intensity, crisp illumination. After one hour of operation, the Moving Head Beam automatically initiates a cooling cycle to effectively protect the lifespan of the light source.

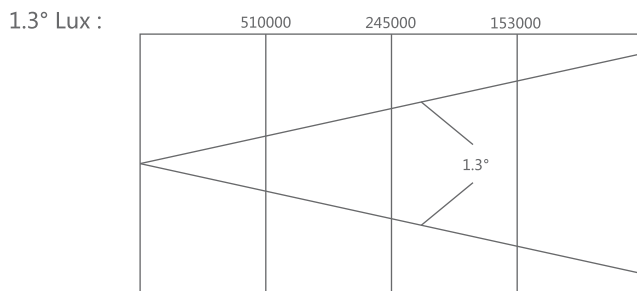

Distance(m) : 0 10 15 20
1.3° Diameter(cm) : 0 35 57 75

OPTICAL PATH LENS

The YR-295B Moving Head Beam is equipped with a compound optical path lens. The entire lamp's beam angle is a narrow 1.3 degrees, resulting in a focused and sharp beam.

POWERFUL MOTOR:

Equipped with a three-phase motor rotation system, the light is capable of panning 540° in 1.9 seconds and tilting 270° in 1.0 second. Combined with electronic correction, it ensures fast and accurate scanning performance.



CONVENIENT LCD DISPLAY

The Moving Head Beam 295W features an intelligent LCD screen that supports inverted display, Chinese and English language switching, lighting time display, error checking, and software version information, making it easy to customize and manage settings.

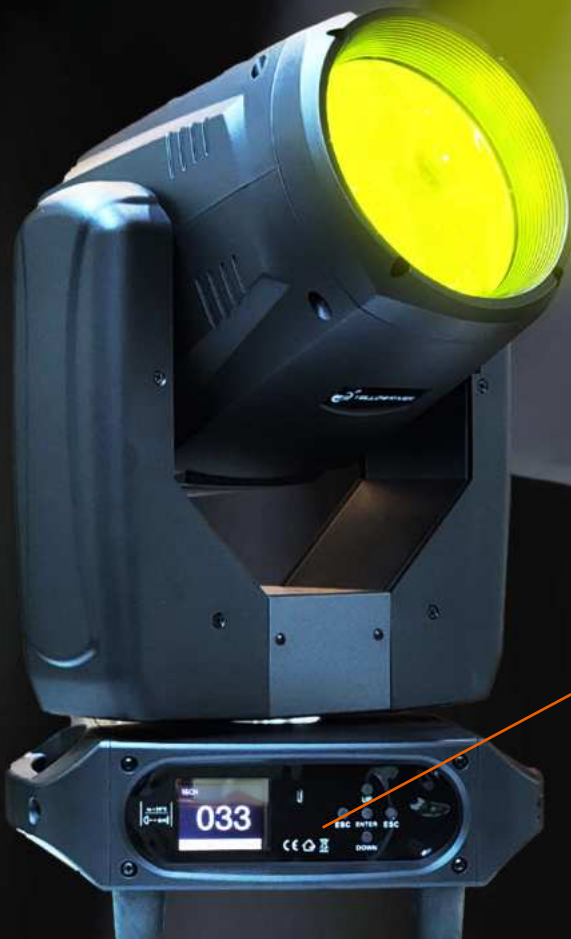

Battery charging port to pre-set up the LCD screen

DIVERSE AND ATTRACTIVE LIGHTING EFFECTS

The YR-295B Moving Head Beam is an indispensable creative tool for any performance. With 14 basic colors, 13 gobos, and a variety of prism effects, the light creates millions of stunning colors, images, and special effects. From sharp beams to ethereal fog effects, the 295B will bring your space to life with vivid colors.

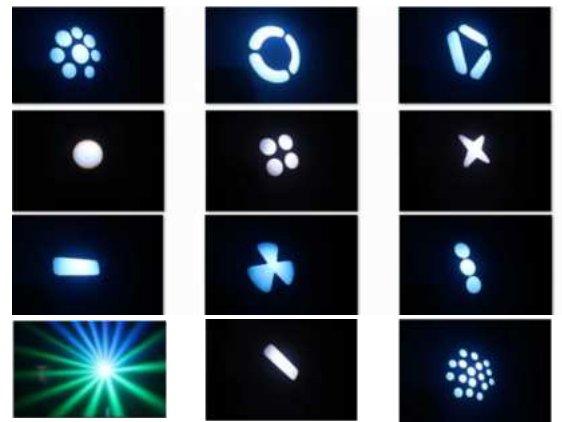

FIXED CLAMP IS SAFE AND CONVENIENT

The lamp features a robust metal locking mechanism at its base, facilitating quick and secure attachment to the stage lighting setup

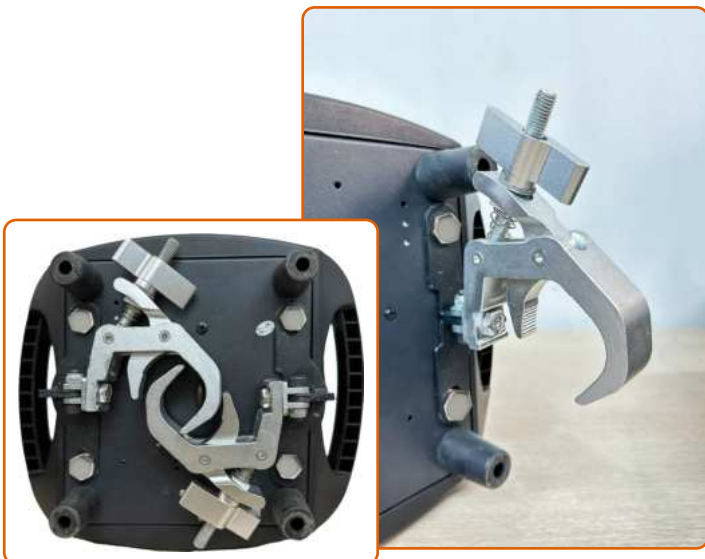

PRODUCT PARAMETERS

Electrical	Voltage	110V ~240V
	Power consumption	450W
Light Source	Lamp	295W
	Color temperature	7800K
Control Mode	DMX512	16ch/20ch
	Master/slave	✓
	Auto	✓
	RDM	✓
Optical System	Gobo wheel	13 fixed gobo+white
	Color wheel	14 colors+white + semi color effects
	Six-color wheel	1pcs, work with a prism can present the effect of six-clor prism
	Prism Wheel1	1 pcs three layers honeycomb prism
	Prism Wheel2	1pcs 16 prism
	Frost	1pc frost glass
	Shutter	1-13t/s
	Dimmer	0-100%
	Focus	✓
	Beam angle	1.3°, Linear focus
Featured Effect	1 pcs 14-color+white wheel+semi color effects 1 pcs three layers honeycomb prism ,1pcs 16 prism	
Touch Screen Display	Reversible display, English-Chinese language switchable,automatic screen,off/lasting bright screen,record lighting time, the software version information,fault inspection, restore factory Settings	
Safety Protection	Will cut off the power automatically when the fixtiure is overheating or with system error	
Machine W. Size	29*23.5*49.5cm	
Net Weight	13.5kg	



**CÔNG TY CỔ PHẦN PHÁT TRIỂN
ĐẦU TƯ THƯƠNG MẠI VÀ DỊCH VỤ HỒ GIA**

Trụ sở: Số 2, ngách 20, ngõ 77 Phố Lụa, Tổ Dân Phố Hồng Phong,
P. Vạn Phúc, Q.Hà Đông, Tp.Hà Nội

VPGD: PB16-08 và PB16-10 Vinhomes Ocean Park, Hưng Yên

Địa chỉ kho: Số 11 TT3.2 Khu đô thị Ao Sào, Phường Thịnh Liệt,
Quận Hoàng Mai, Hà Nội

Email: ceo@skv.lighting Hotline: 0968.240.789



Zalo



Website



Tiktok