

CABIN LED RENTAL

V ECO SERIES

Indoor/Outdoor High Quality & Affordable Events LED Screen



Ultra-thin and Light weight



Fast heat dissipation



High strength



Easy installation



High precision



Easy maintenance

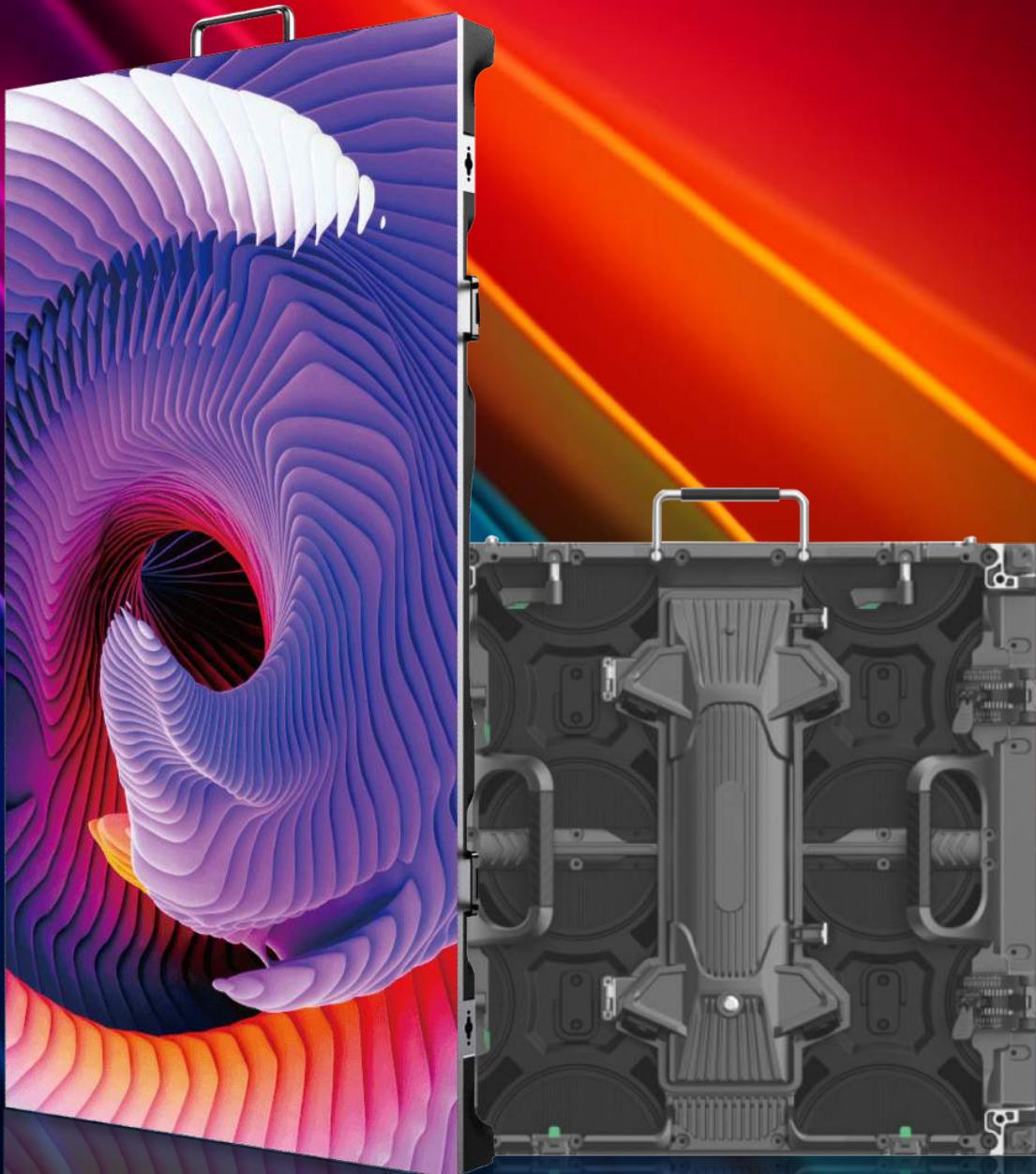

V Eco Series

Cabin led V Eco Series was born to create a large indoor or outdoor stage. The 500*500mm panel is flexible and convenient. The 500*1000mm large size panel can help customers to quickly build a large screen in a short time. Reduces labor and time, resulting in overall cost savings.

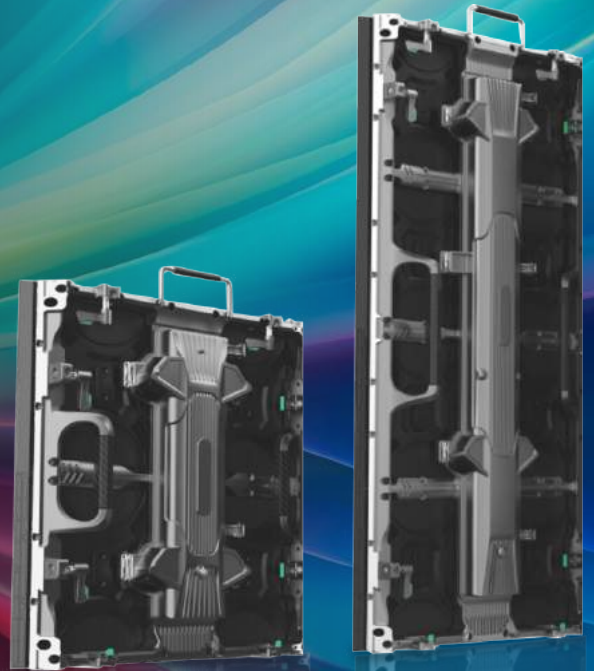

Ultra Thin & Light Design

V Eco Series uses die-cast aluminum material, sturdy and light. Multiple LED cabins can be stacked on top of each other to create a super large LED screen, without burdening the system

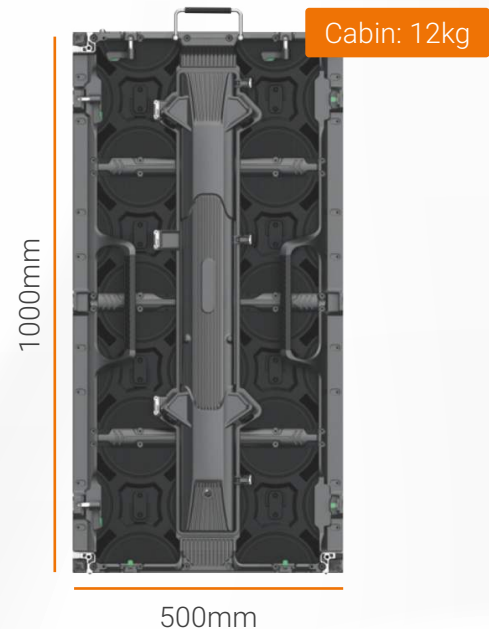
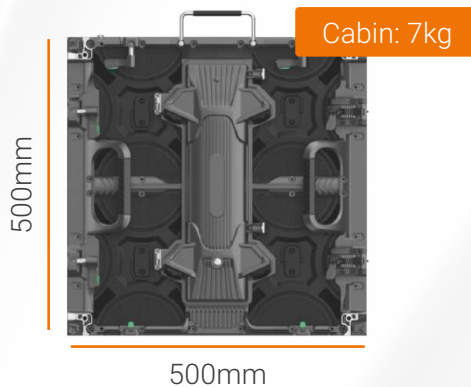
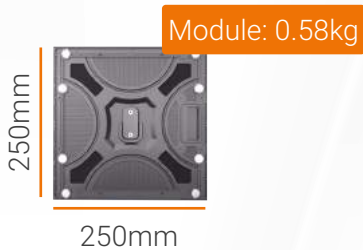

Anti-collision Design

The V Eco series features an anti-collision design with flip-over protective corners and edge protrusion structures, preventing direct collision between LEDs and the ground to effectively protect edge LEDs.



Anti-Collision on four corners



Avoid direct contact, protect LED bulbs

Fast Locking System

The V Eco series features a fast locking system with an instant feedback mechanism and magnets on the top and bottom of the modulares, allowing the operator to set up quickly.

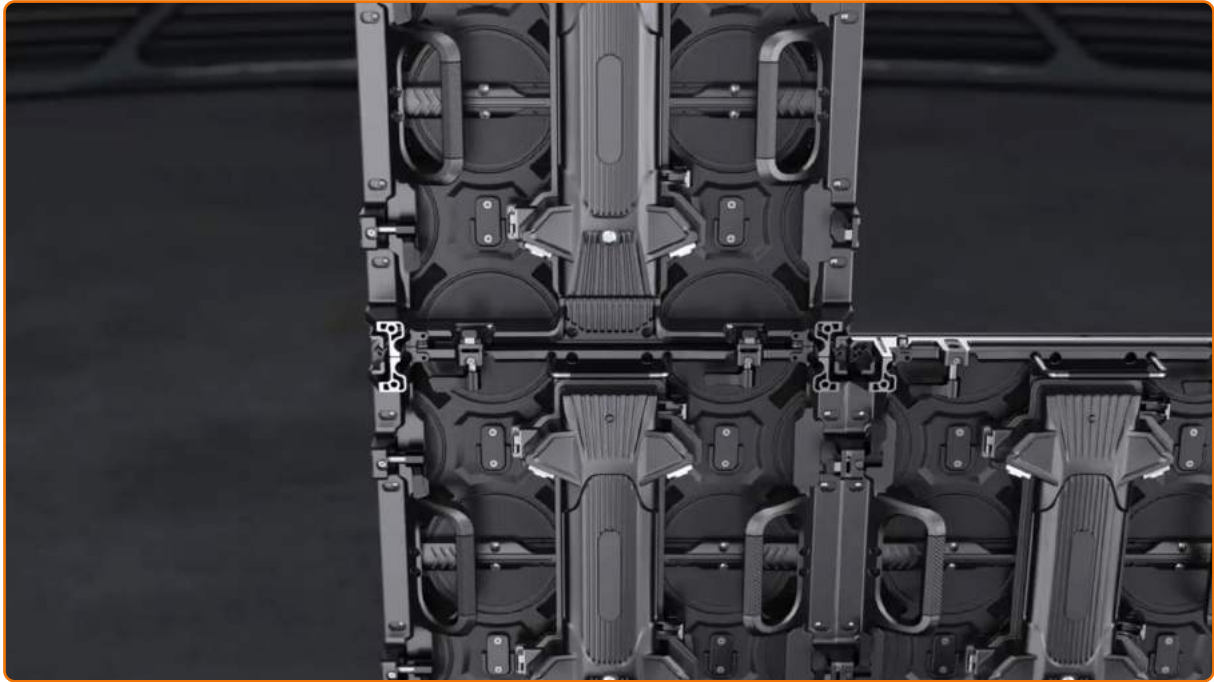

Amazing Visual Experience

The V Eco series offers a range of products with high brightness and refresh rates, perfect for creating stunning events. The brightness of indoor products ranges from 800nits to 1000nits depending on the best effects. Outdoor V-Eco 3.9 brightness is 4200nits. All products have a refresh rate of at least ≥ 7680 Hz.



Grayscale:

13 bit 

Brightness:

800-5000 nits 

Refresh rate:

≥ 7680 Hz 

Excellent Curving Capabilities

Featuring a durable curve locking system, the V Eco series supports concave and convex connections to create various shapes. The adjustment angle range is from -10° to $+15^{\circ}$ & 45° allows for creative and customized stage configurations.

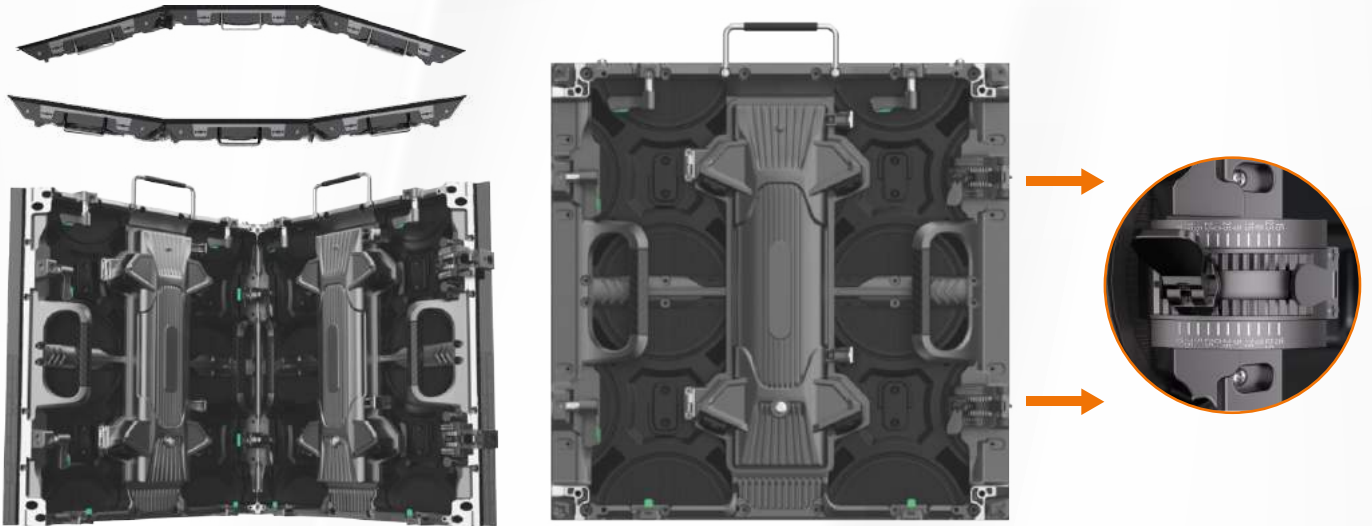

45° assembly

Mixed Splicing

500 x 500 mm and 500 x 1000 mm cabinets can be easily connected horizontally and vertically for different configurations.

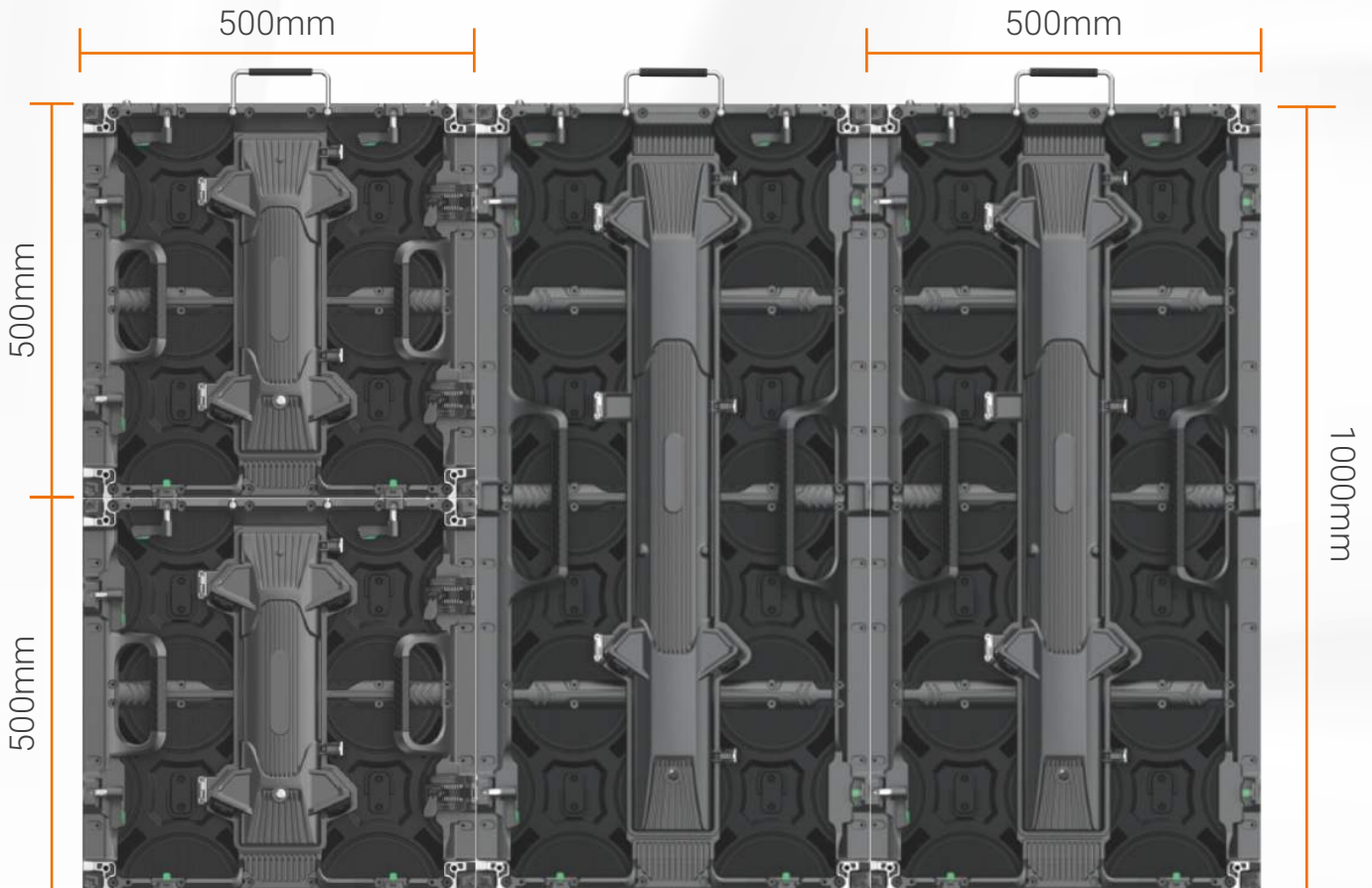

Specification Parameter

Product	V-ECO-2.6 (Indoor)	V-ECO-2.9 (Indoor)	V-ECO-3.9 (Indoor)	V-ECO-3.9 (Outdoor)
Pixel Pitch (mm)	2.604	2.97	3.91	3.91
Cabinet size (WxHxD/mm)	500x500x88 500x1000x88			
Cabinet Resolution	192x192 192x384	168x168 168x336	128x128 128x256	128x128 128x256
Cabinet Material	Die Casting Aluminum			
Cabinet Weight (Kg)	6.75/11.5	6.75/11.5	6.75/11.5	7/12
Brightness (Nits)	800	800	800	≥5000
Refresh Rate (Hz)	≥7680			
Gray Scale (Bit)	13			
IP Rating (Front/Rear)	IP40/IP21	IP40/IP21	IP40/IP21	IP65/54
Max./Avg Power Consumption (W/m ²)	480/160	480/160	472/157	735/245
Curve	45°/-10°/15°			



**CÔNG TY CỔ PHẦN PHÁT TRIỂN
ĐẦU TƯ THƯƠNG MẠI VÀ DỊCH VỤ HỒ GIA**

Trụ sở: Số 2, ngách 20, ngõ 77 Phố Lụa, Tổ Dân Phố Hồng Phong,
P. Vạn Phúc, Q. Hà Đông, Tp. Hà Nội

VPGD: PB16-08 và PB16-10 Vinhomes Ocean Park, Hưng Yên

Địa chỉ kho: Số 11 TT3.2 Khu đô thị Ao Sào, Phường Thịnh Liệt,
Quận Hoàng Mai, Hà Nội

Email: ceo@skv.lighting Hotline: 0968.240.789



Zalo



Website



Tiktok